

TECHNICAL INFORMATION BULLETIN



FRANKLIN
COMPUTER CORPORATION

BULLETIN #: DSK-002 DATE: 09/30/82
SUBJECT: ACE 10 SUBSYSTEM ALIGNMENT PROCEDURES

7030 Colonial Highway
Pennsauken, NJ 08109
609-488-1700

1. INTRODUCTION

Errors when reading or writing diskettes can be caused by a number of factors. These include incorrect operating procedures, faulty programming, damaged diskettes, airborne contaminants, electrical interference, and misaligned disk drives. This Bulletin will deal with those problems associated with mechanical and electrical misalignment of the disk drive and controller units.

2. EQUIPMENT REQUIRED

- A. Franklin ACE Computer and monitor.
- B. Franklin ACE 10 Disk Drive with Controller.
- C. Dual trace oscilloscope with 2 probes.
- D. Dealer Diagnostic Diskette.
- E. Alignment Diskette (Dysan 208/10 or equivalent).
- F. Blank diskette.

3. SETUP

Install the computer, monitor, and the disk drive sub assembly in the normal manner. Leave the computer top cover off to allow access to the disk controller. Place the monitor and disk drive to the side of the computer. Remove the disk drive cover assembly and the disk drive bottom plate.

If you are using an oscilloscope in this procedure, connect the scope probes and turn the power on.

4. DISK CONTROLLER ADJUSTMENT

Connect a disk drive to the drive 1 position of the disk controller. Jumper the two left pins of J4 together (SEE FIGURE 3). Do not disturb the two right pins. They must also be jumpered together.

Apply power to the computer. The computer will initialize and the floating point basic prompt will be displayed.

Type the following:

CALL 50688 (RETURN)
AAW (RETURN) (ESC)

Connect the oscilloscope A channel probe to U7 pin 5 on the disk controller. Adjust R1 on the disk controller for a pulse width of 5.4 micro seconds.

Type the following:

99W (RETURN) (ESC)

Connect the oscilloscope A channel probe to U7 pin 13 on the disk controller. Adjust R2 on the disk controller for a pulse width of 3.8 micro seconds.

5. DISK MOTOR SPEED ADJUSTMENT

The disk drive motor speed can be adjusted in two ways. The speed can be set by visually observing the timing disk on the bottom of the drive under fluorescent lighting, or it can be set with the use of the Dealer Diagnostic Diskette.

A. VISUAL ADJUSTMENT

Position the drive so that the strobe disk on the bottom can be seen (you must be in an area lighted by fluorescents for this procedure to be effective).

Install a blank diskette and start the drive motor by selecting the drive. This can be done by asking for a catalog of the diskette or by momentarily turning the computer power off and on.

Adjust the pot on the small PC board mounted on the rear of the disk drive using a small flat screwdriver. Turn the pot until the outside band of dark lines appears motionless.

B. DEALER DIAGNOSTIC SPEED ADJUSTMENT

Install the Dealer Diagnostic Diskette in the disk drive and reset the computer to boot the diskette. The monitor screen will clear and display the diagnostic menu. Select the disk tests from the menu. A secondary disk menu will then be displayed. Replace the diagnostic diskette with a blank initialized diskette. Select the speed test from the secondary menu. The drive under test will activate and the speed of the drive, in miliseconds, will be displayed. Adjust the pot on the rear of the disk drive for a displayed setting of 200 ms.

6. CARRIAGE LIMIT ADJUSTMENT

A. Remove the disk drive analog card and set it aside.

B. Rotate the head cam actuator until the zero detent dimple is directly opposite and centered on the cam follower. Move the head carriage forward until the ball in the cam follower drops into the zero detent.

With the assembly in this position, adjust the carriage limiter for a clearance of .020 inch between the carriage limiter and the motor shaft stop. See figure 1A.

- C. The proper setting can be verified by rotating the head cam actuator until the motor shaft stop and the carriage limiter are touching. At this position, the relationship of the cam follower to the zero detent should be as shown in figure 1B.

7. WRITE PROTECT

Boot on the Dealer Diagnostic diskette and select the write protect test from the secondary disk menu. While inserting and removing the diskette, observe that the write protect status on the monitor is HIGH with the diskette inserted all the way in the drive and LOW if you move the diskette from its fully inserted position. Repeat this test a few times to insure that the status is always correct. Adjust the switch if necessary.

8. AZIMUTH TEST

- A. Connect the oscilloscope probes to TP1 and TP2 as shown in figure 2. Connect a ground from the scope to the - (minus) side of C14. Set the scope controls to measure differential signals (A + B with the B channel inverted). Make certain that both A and B channels are set to the same volts per division.
- B. Boot the computer on the Dealer Diagnostic diskette.
- C. Remove the Dealer Diagnostic diskette and insert the Alignment Diskette.
- D. Select the AZIMUTH test from the disk test submenu.
- E. Adjust the oscilloscope so that a steady display is shown. The display should look similar to those shown in Figure 4. The display labeled A is the ideal condition, however the other three displays are also acceptable. If the drive produces a display with the first or fourth bursts larger than the second or third, the drive does not have an acceptable azimuth reading.

NOTE: THIS IS A GO - NO GO TEST. IF ACCEPTABLE AZIMUTH IS NOT DISPLAYED, THE DRIVE SHOULD BE RETURNED TO FRANKLIN COMPUTER CORPORATION.

9. RADIAL ALIGNMENT

- A. Boot the computer on the Dealer Diagnostic diskette.
- B. Select the ALIGNMENT test from the disk submenu.

- C. Remove the Dealer Diagnostic diskette and insert the Alignment Diskette.
- D. With the scope probes connected as for paragraph 8, adjust the scope to give a steady display of at least two lobes as shown in figure 5. A time base of 10 msec/div will usually give the proper display.
- E. The optimum display is shown in figure 5B where both lobes are of equal amplitude. If one lobe is smaller and is not within 80% the size of the larger lobe, an adjustment will be necessary.

With the drive still running, carefully turn the disk drive on its side. Locate the two slotted screws holding the stepper motor to the chassis of the drive and loosen them slightly. While observing the oscilloscope display, rotate the stepper motor carefully until the two lobes are equal in size. Tighten the two screws and observe that the two lobes are still the same size. Loosen and adjust as necessary.

Check the alignment by first pressing the right arrow key and then the left arrow key. If the lobes are not still not within 80% of each other the drive will have to be realigned and checked again. It may be necessary to split the difference in the error to remain within the 80% limit. The final oscilloscope display should look like figure 5B.

10. NOTE: THE POTENTIOMETER ADJUSTMENT ON THE DISK DRIVE ANALOG CARD IS FOR WRITE CURRENT TO THE HEAD ASSEMBLY. THIS POT ADJUSTMENT IS CURRENTLY A FACTORY ONLY ADJUSTMENT. DO NOT UNDER ANY CIRCUMSTANCES CHANGE THE SETTING OF THIS POT.

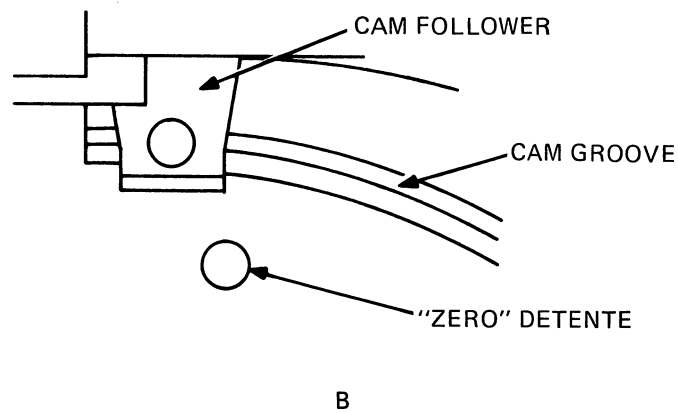
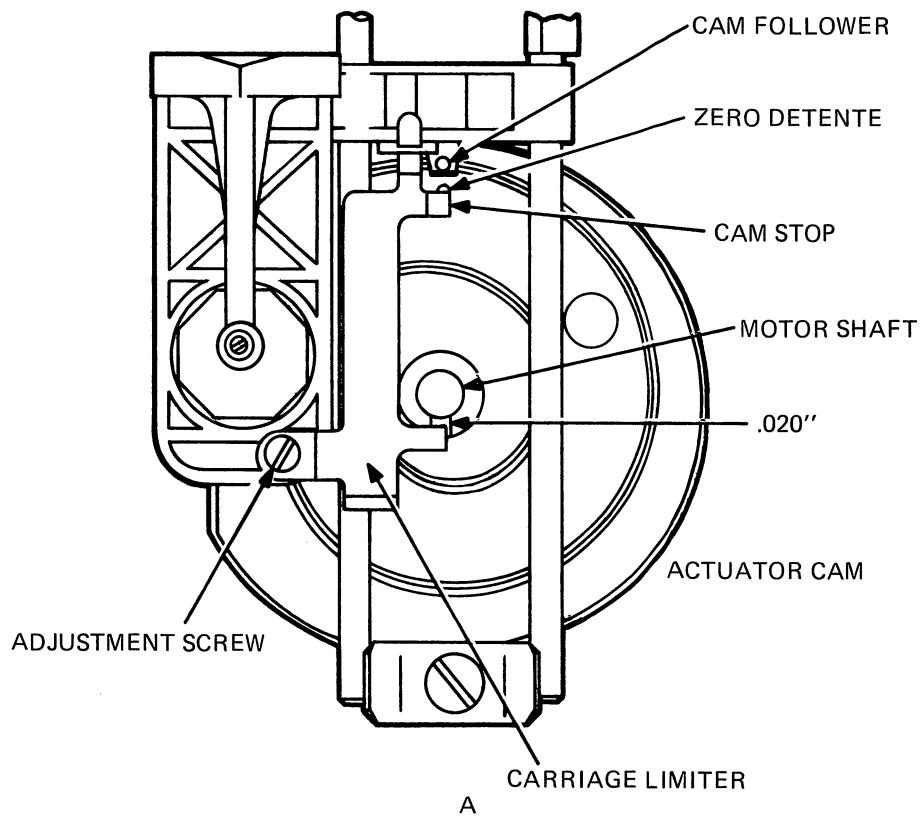

Figure 1. Track Zero Detent/Carriage Limit Adjustment.

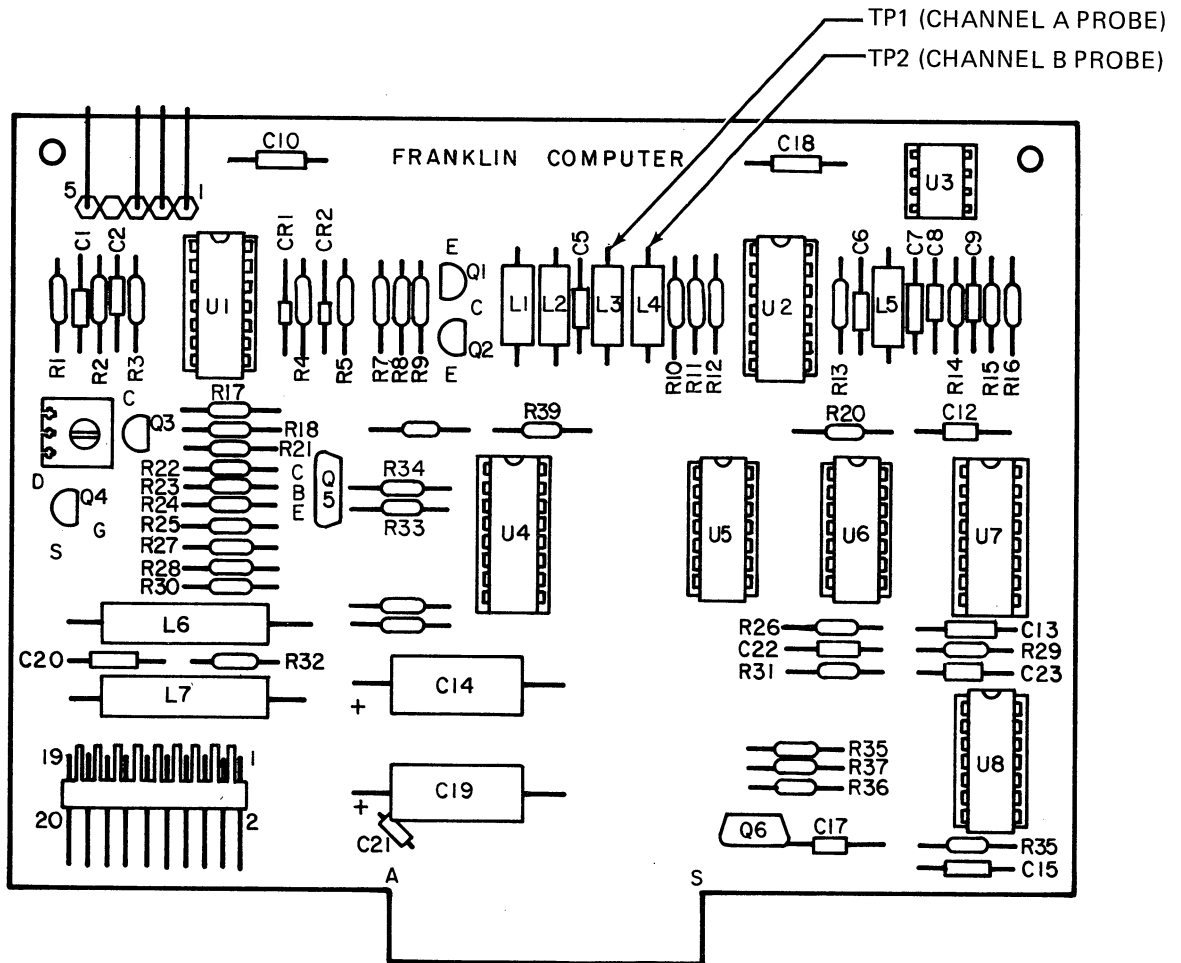

Figure 2. ACE 10 Disk Analog Board.

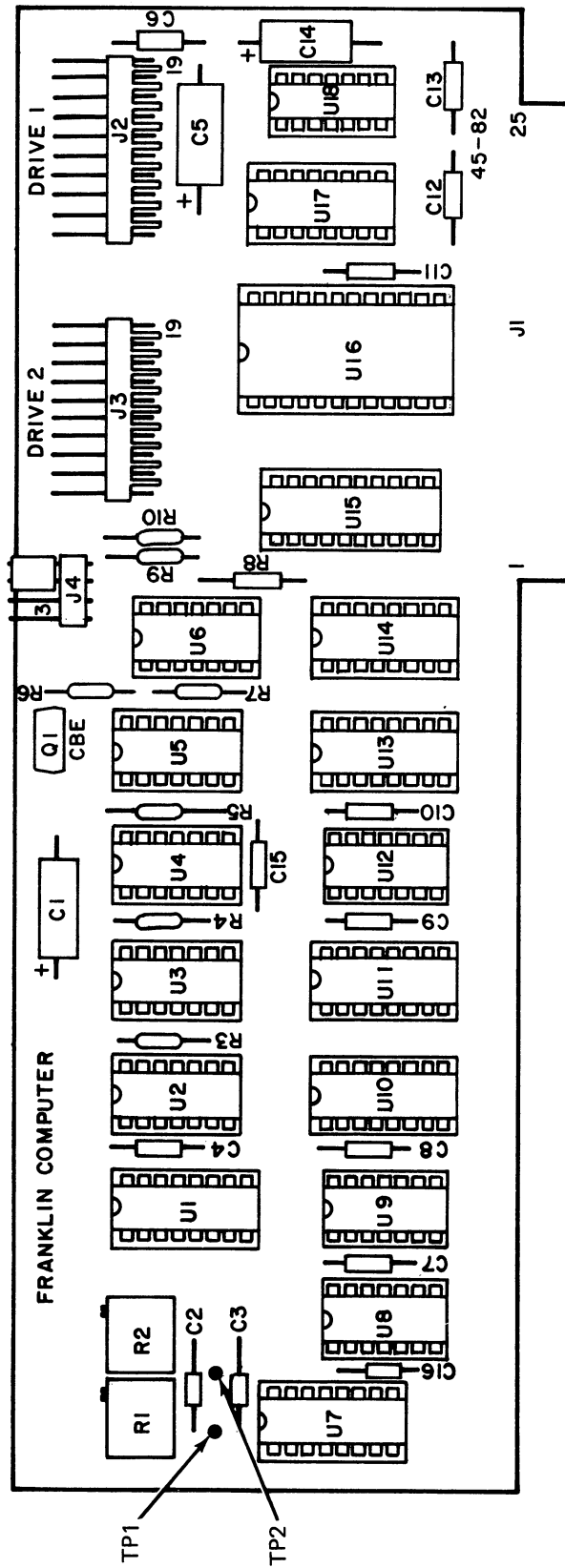

Figure 3. ACE 10 Disk Controller.

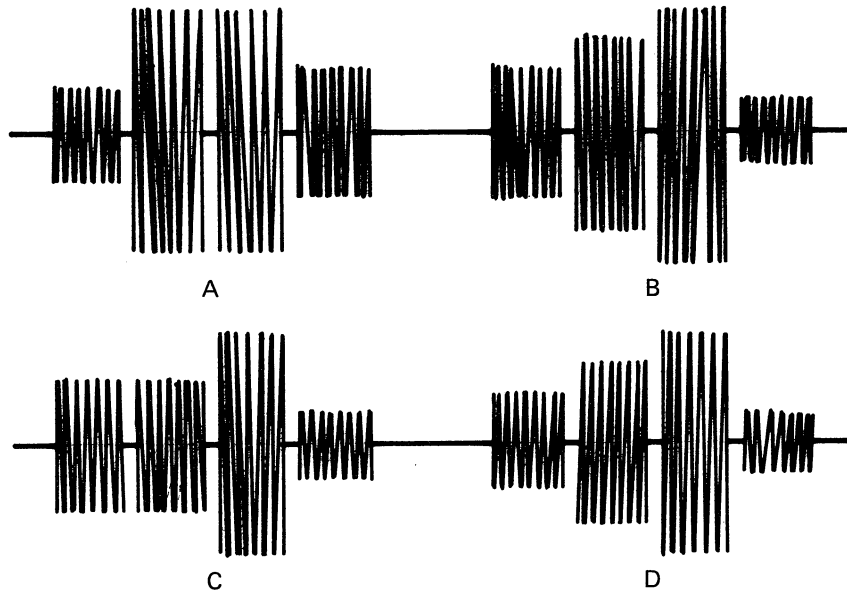

Figure 4. ACE 10 Floppy Disk Azimuth Test.

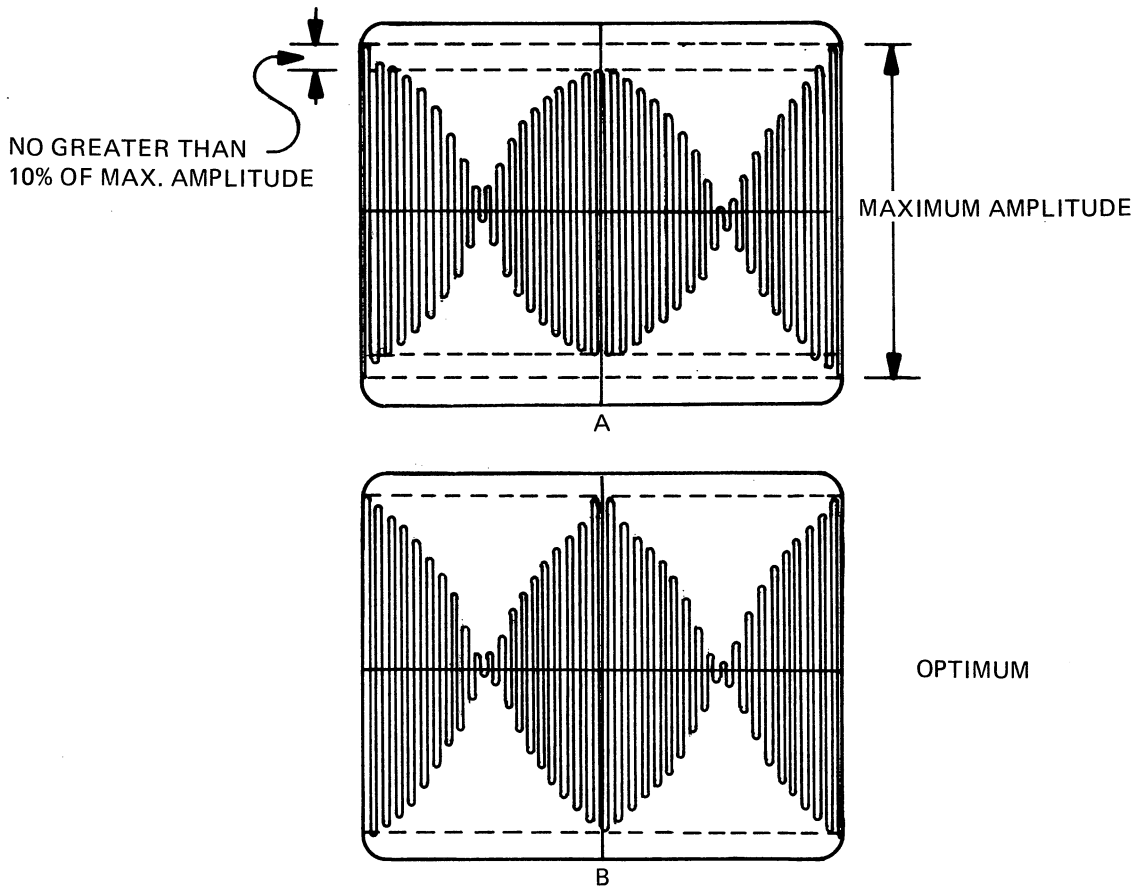
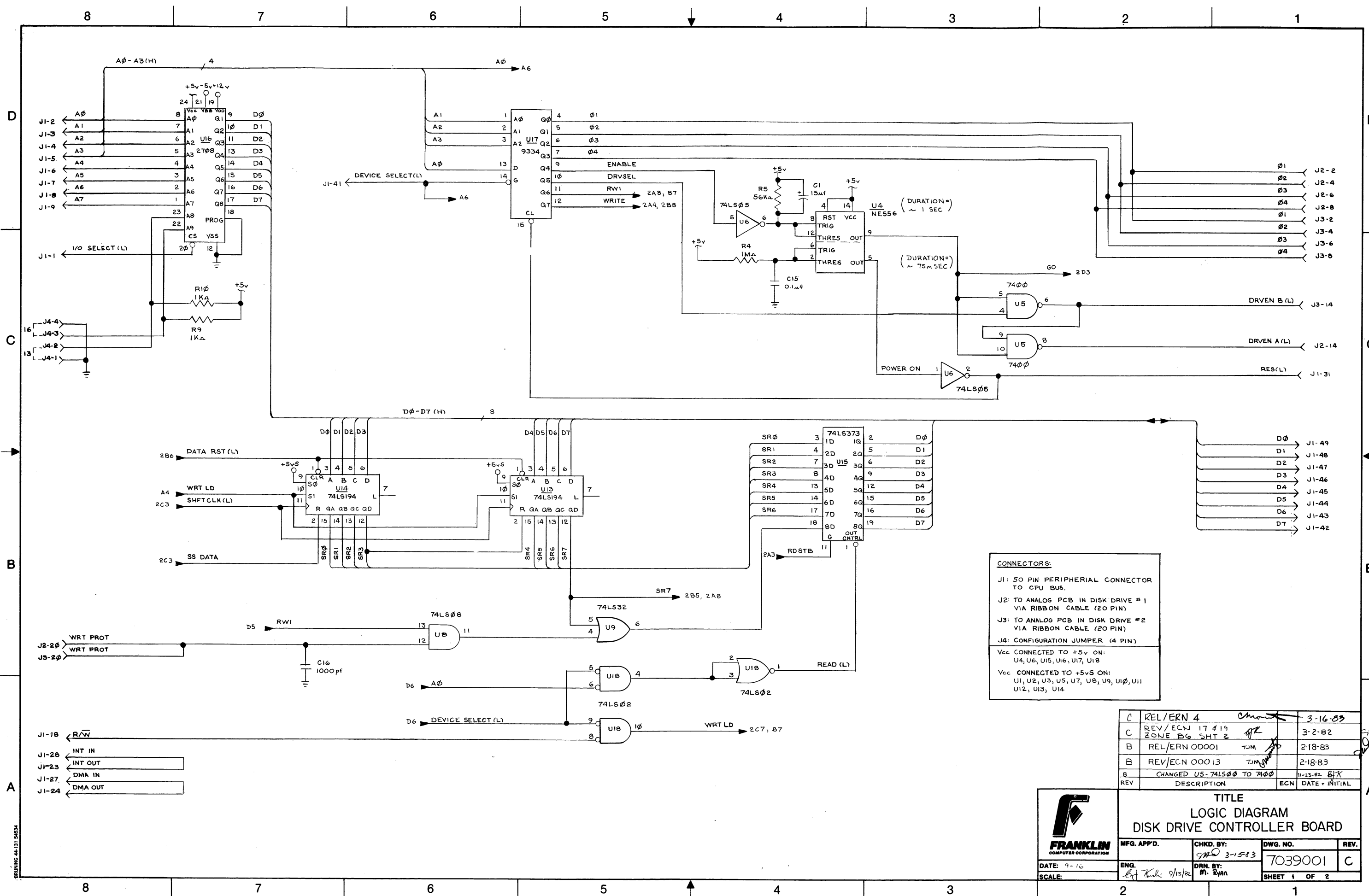

Figure 5. ACE 10 Floppy Disk Radial Alignment.



CONNECTORS:

J1: 50 PIN PERIPHERAL CONNECTOR TO CPU BUS.

J2: TO ANALOG PCB IN DISK DRIVE #1 VIA RIBBON CABLE (20 PIN)

J3: TO ANALOG PCB IN DISK DRIVE #2 VIA RIBBON CABLE (20 PIN)

J4: CONFIGURATION JUMPER (4 PIN)

Vcc CONNECTED TO +5v ON: U4, U6, U15, U16, U17, U18

Vcc CONNECTED TO +5v ON: U1, U2, U3, U5, U7, U8, U9, U10, U11, U12, U13, U14

C	REL/ERN 4	Ch...	3-16-83
C	REV/ECN 17 & 19	gfk	3-2-82
B	REL/ERN 0001	TJM	2-18-83
B	REV/ECN 00013	TJM	2-18-83
B	CHANGED U5-74LS00 TO 7400	gfk	11-23-82
REV	DESCRIPTION	ECN	DATE + INITIAL

FRANKLIN COMPUTER CORPORATION

TITLE
LOGIC DIAGRAM
DISK DRIVE CONTROLLER BOARD

DATE: 9-16
SCALE:

ENG. *gfk* 9/15/82

CHKD. BY: *gfk* 3-15-83

DRN. BY: M. RYAN

MFG. APP'D.

DWG. NO. 7039001

REV. C

SHEET 1 OF 2

BRUNING 44-131 54834

