

NOTE: Unless otherwise specified

1. All resistance values are in ohms. +/- 5%, 1/8 watt.
2. All capacitance values are in microfarads.
3. () denotes sheet to sheet references.
4. Cold & hot ground are connected together at two locations, near the RDB connectors and at the sound circuit.

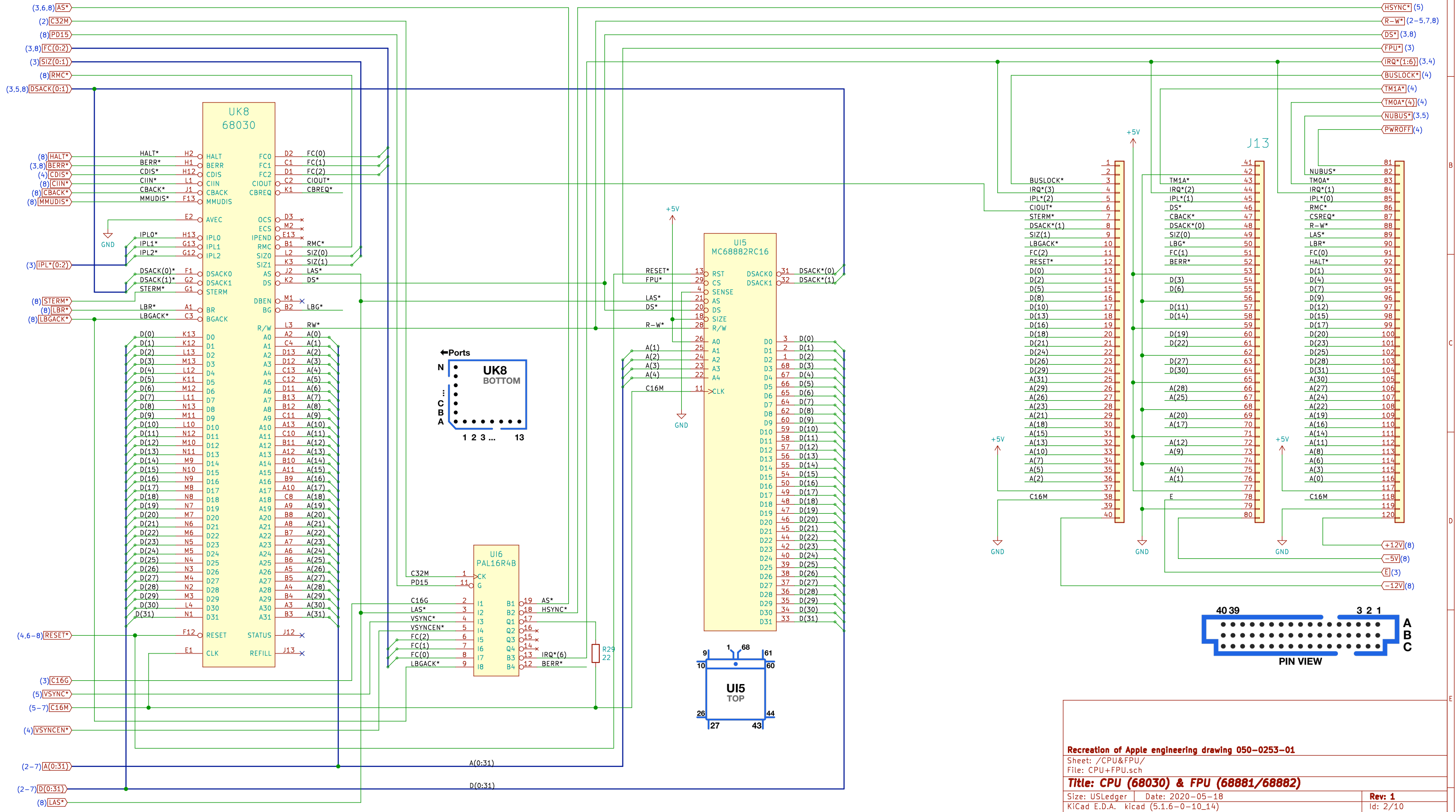

Recreation of Apple engineering drawing 050-0253-01
 Sheet: /CPU&FPU/
 File: CPU+FPU.sch
Title: CPU (68030) & FPU (68881/68882)
 Size: USLedger | Date: 2020-05-18 | **Rev: 1**
 KiCad E.D.A. | kicad (5.1.6-0-10_14) | Id: 2/10

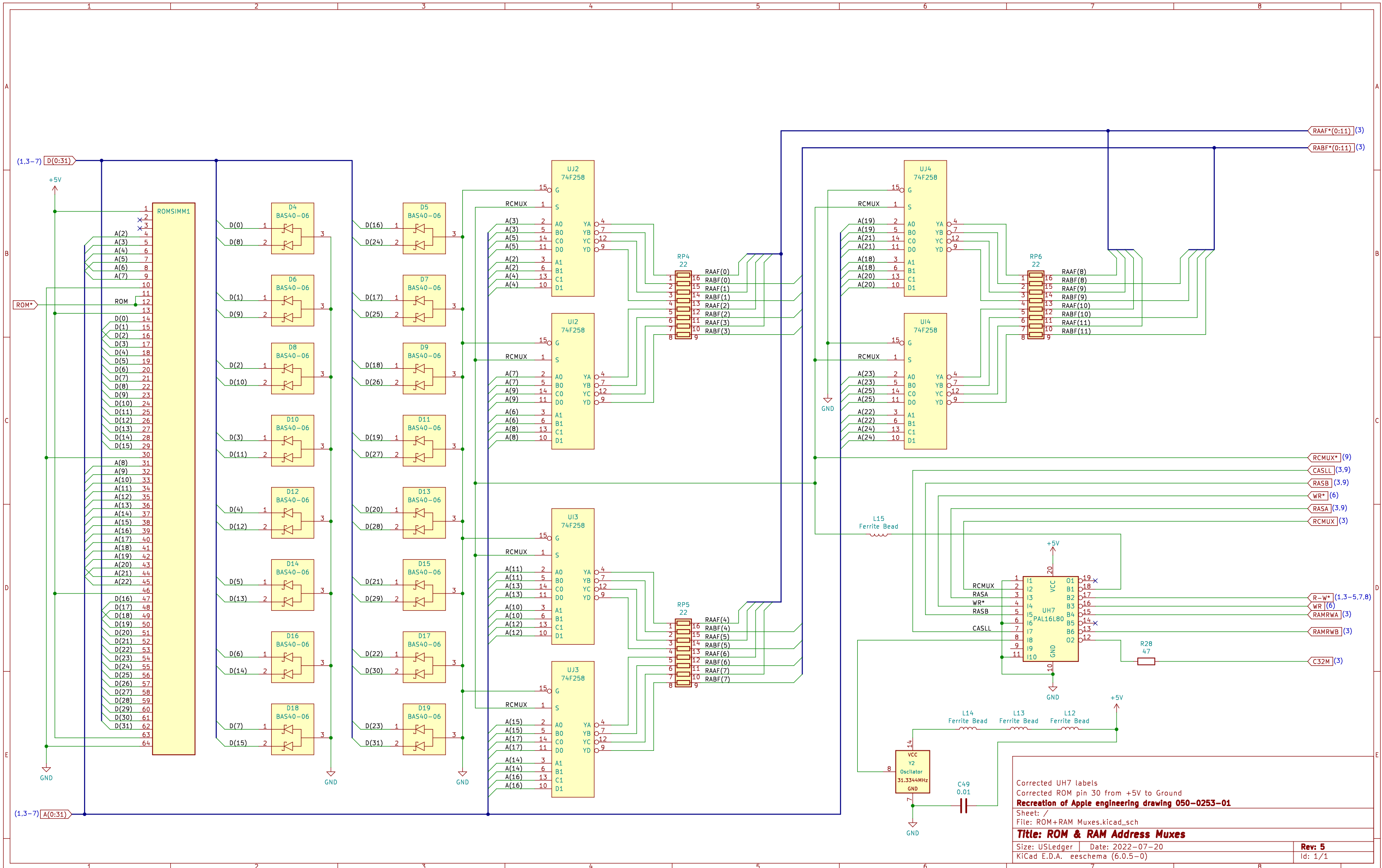

Corrected UH7 labels
 Corrected ROM pin 30 from +5V to Ground
Recreation of Apple engineering drawing 050-0253-01

Sheet: /
 File: ROM+RAM Muxes.kicad_sch
Title: ROM & RAM Address Muxes

Size: USLedger | Date: 2022-07-20
 KiCad E.D.A. eeschema (6.0.5-0)

Rev: 5
 Id: 1/1

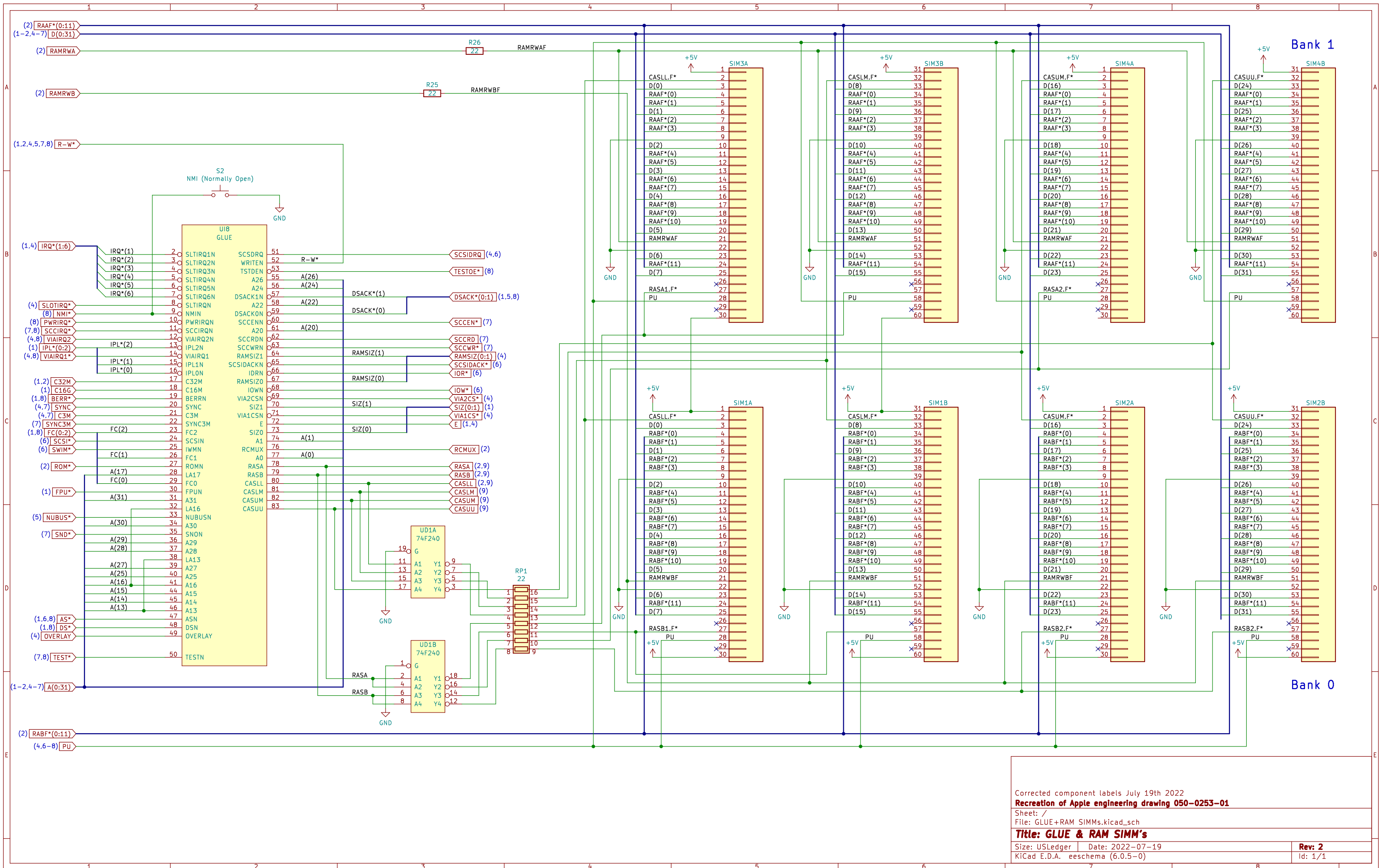

Corrected component labels July 19th 2022
Recreation of Apple engineering drawing 050-0253-01
 Sheet: /
 File: GLUE+RAM SIMMs.kicad_sch
Title: GLUE & RAM SIMM's
 Size: USLdger | Date: 2022-07-19 | **Rev: 2**
 KiCad E.D.A. | eeschema (6.0.5-0) | Id: 1/1

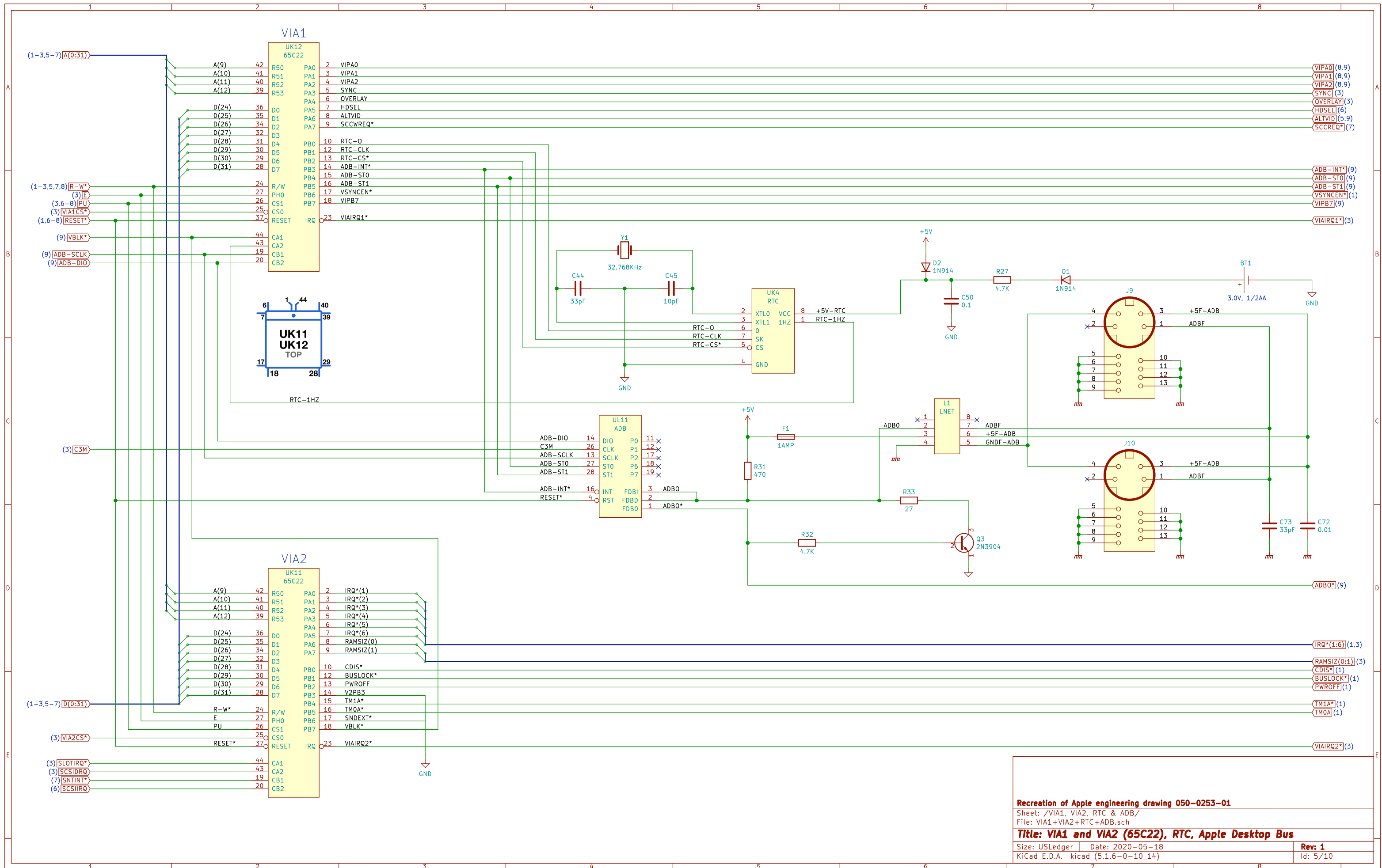

Recreation of Apple engineering drawing 050-0253-01
 Sheet: /VIA1, VIA2, RTC & ADB/
 File: VIA1+VIA2+RTC+ADB.sch
Title: VIA1 and VIA2 (65C22), RTC, Apple Desktop Bus
 Size: USLedger | Date: 2020-05-18 | Rev: 1
 KiCad E.D.A. kicad (5.1.6-0-10_14) | Id: 5/10

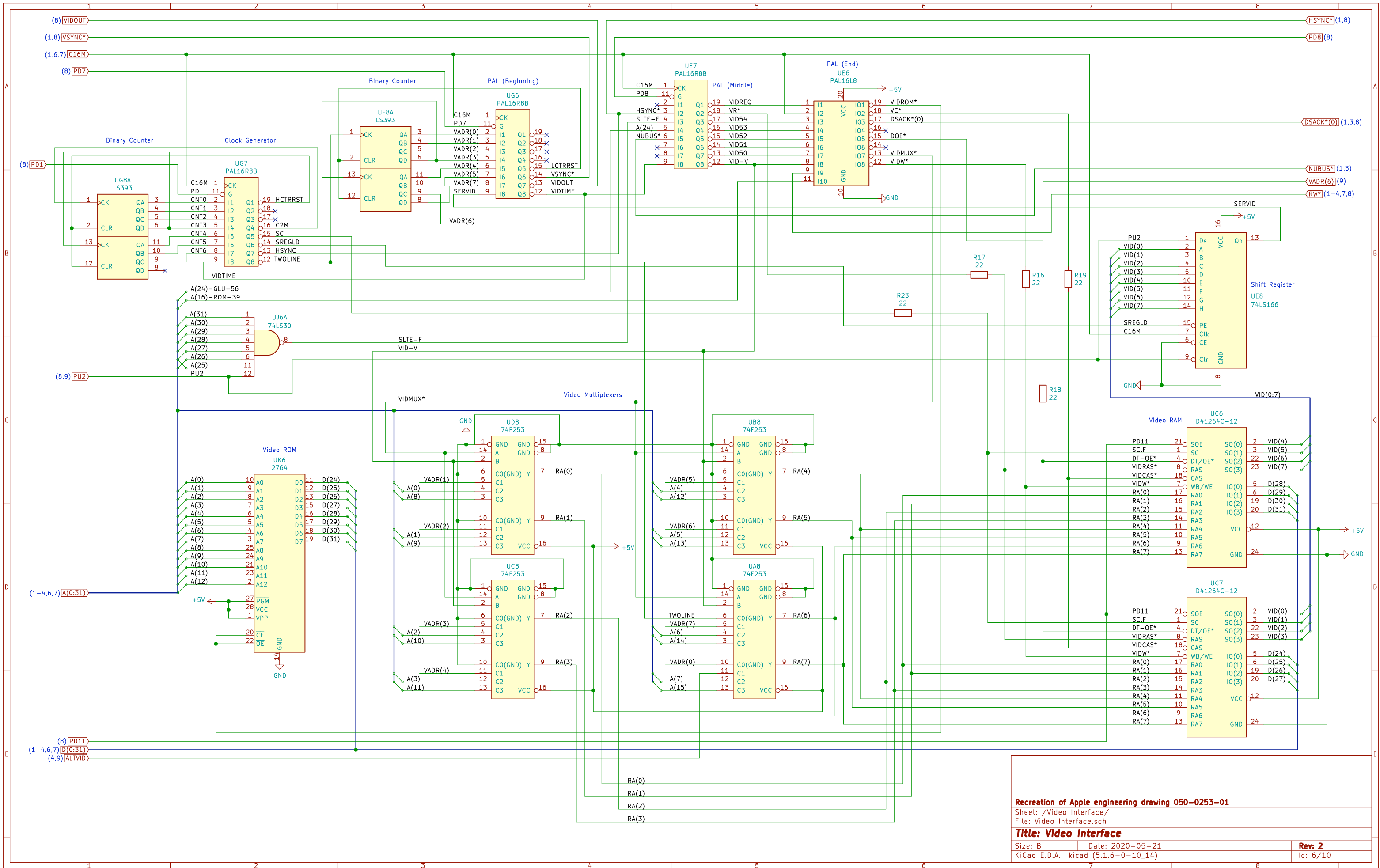

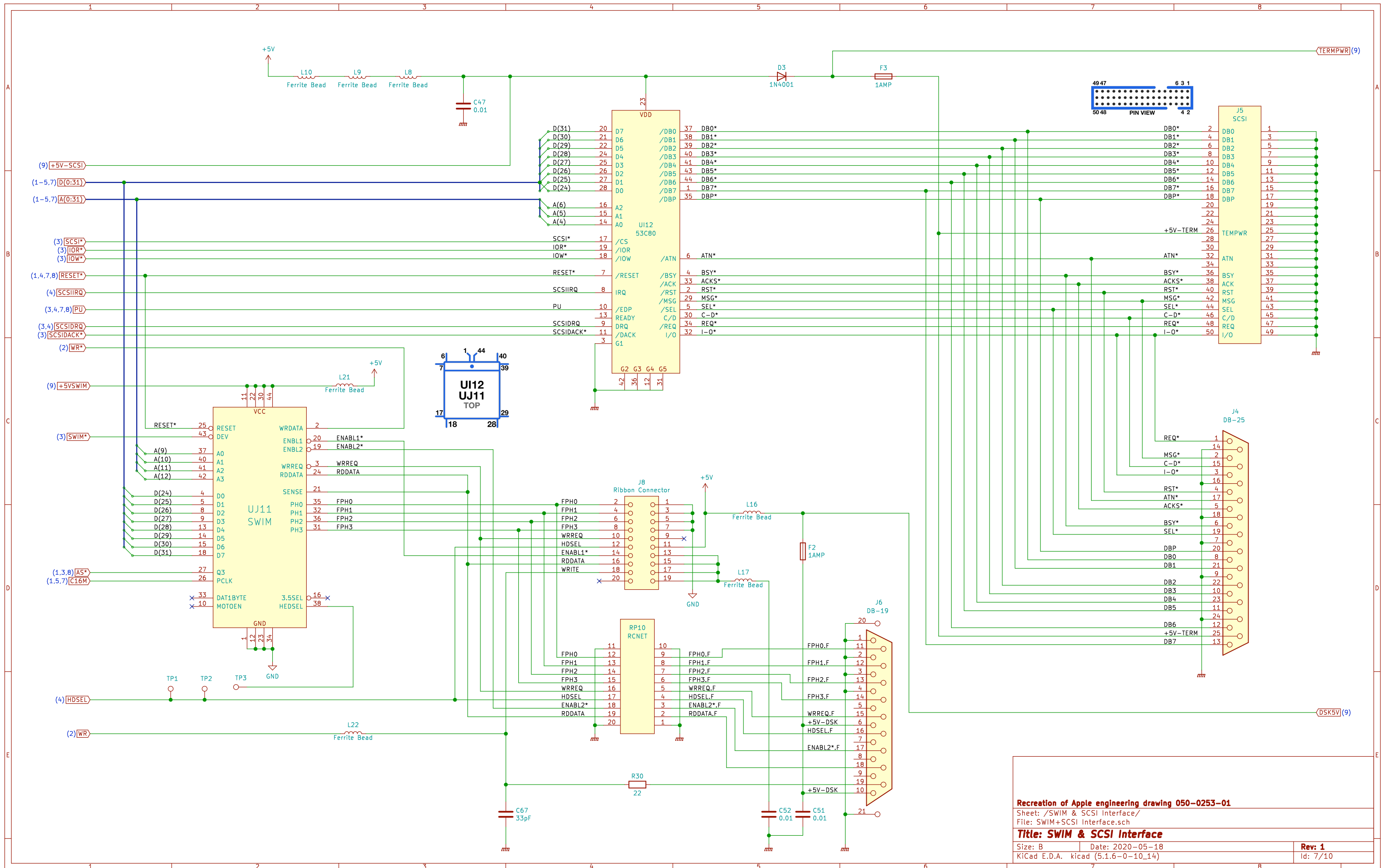

Recreation of Apple engineering drawing 050-0253-01
 Sheet: /SWIM & SCSI Interface/
 File: SWIM+SCSI Interface.sch
Title: SWIM & SCSI Interface
 Size: B Date: 2020-05-18 **Rev: 1**
 KiCad E.D.A. kicad (5.1.6-0-10_14) Id: 7/10

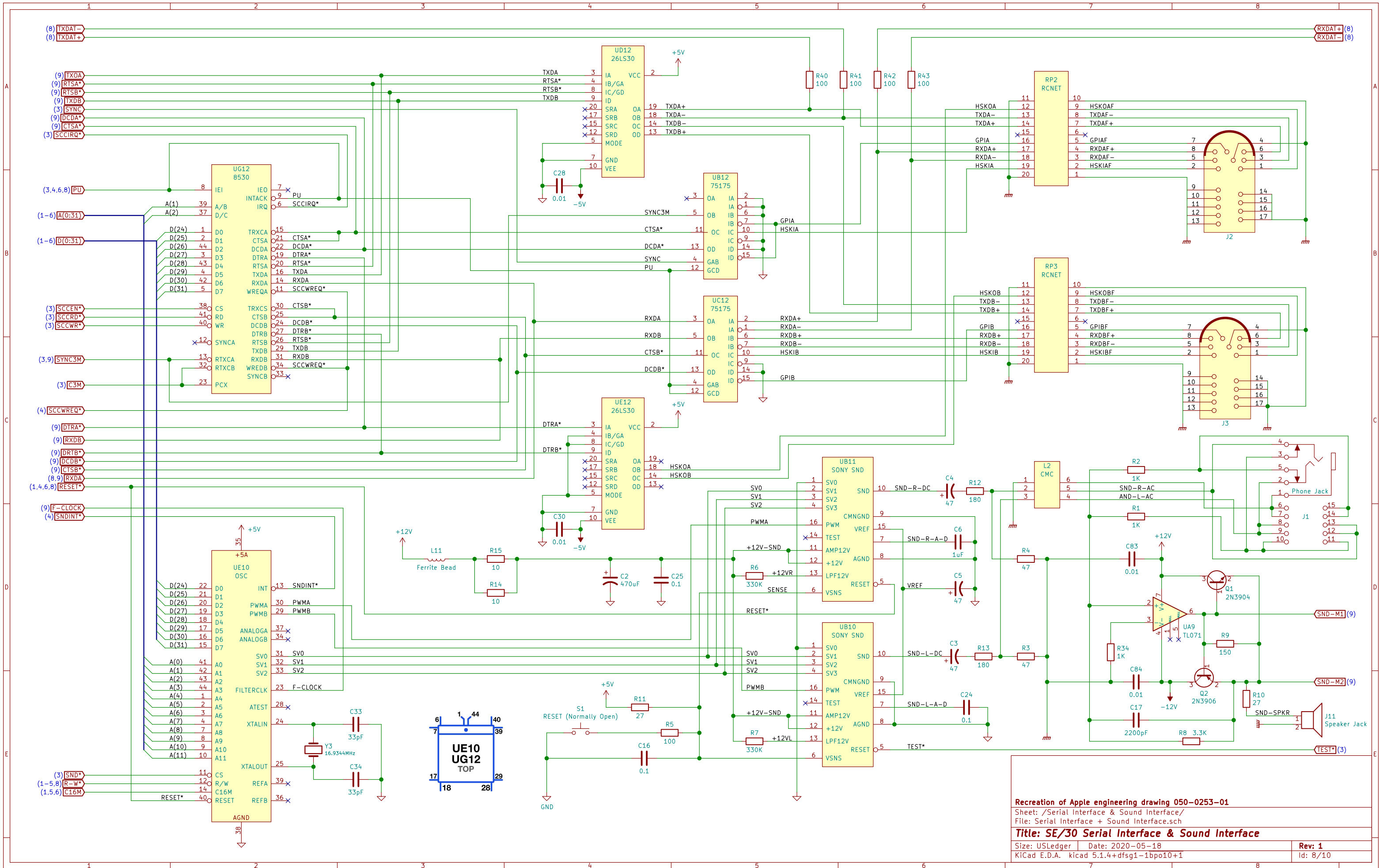

Recreation of Apple engineering drawing 050-0253-01
 Sheet: /Serial Interface & Sound Interface/
 File: Serial Interface + Sound Interface.sch
Title: SE/30 Serial Interface & Sound Interface
 Size: USLdger Date: 2020-05-18 Rev: 1
 KiCad E.D.A. kicad 5.1.4+dfsg1-1bpo10+1 Id: 8/10

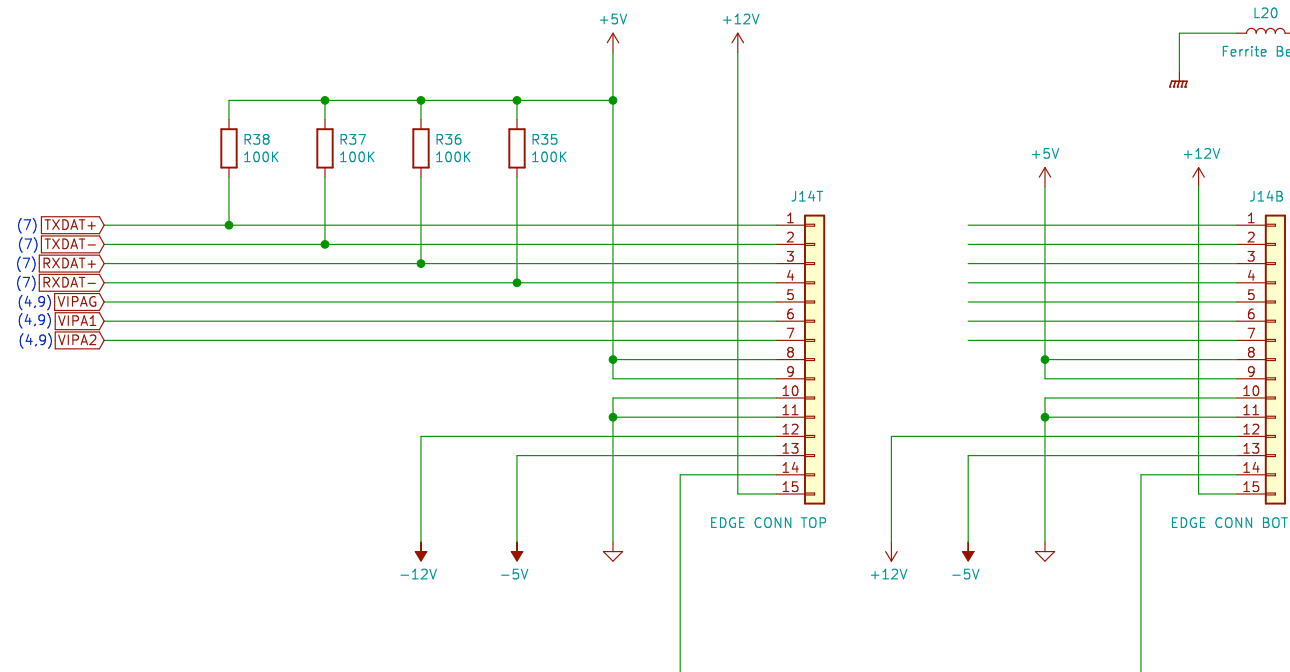
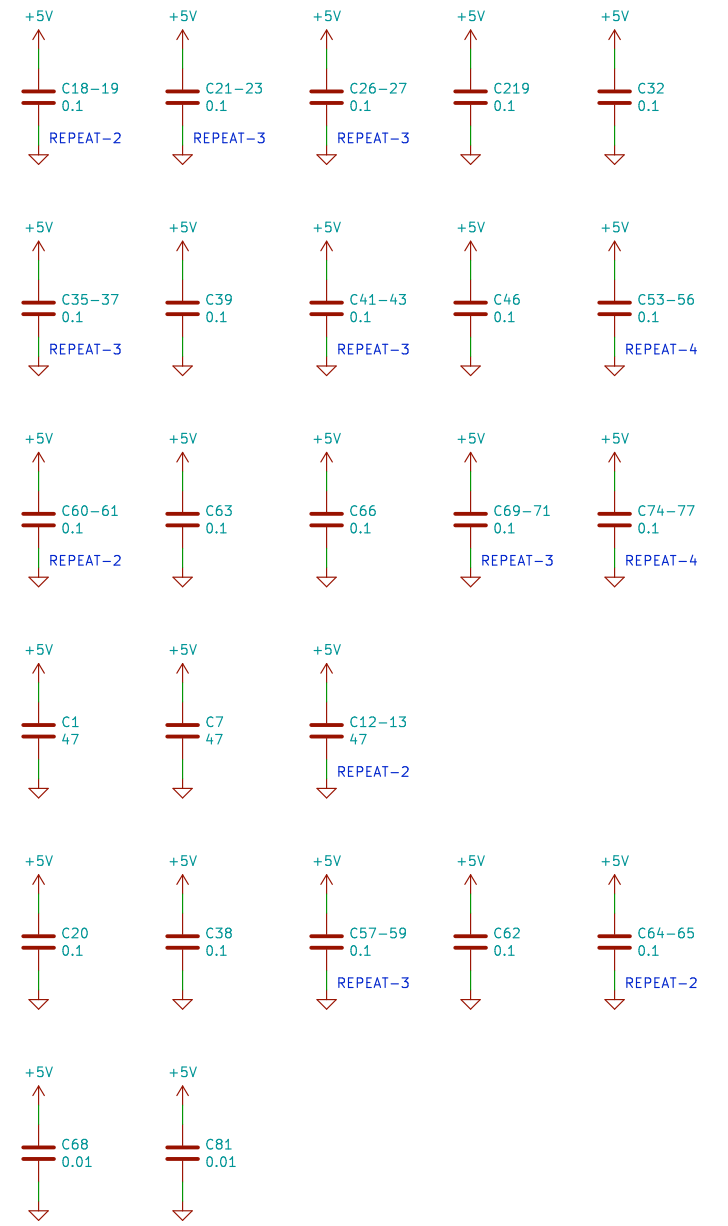
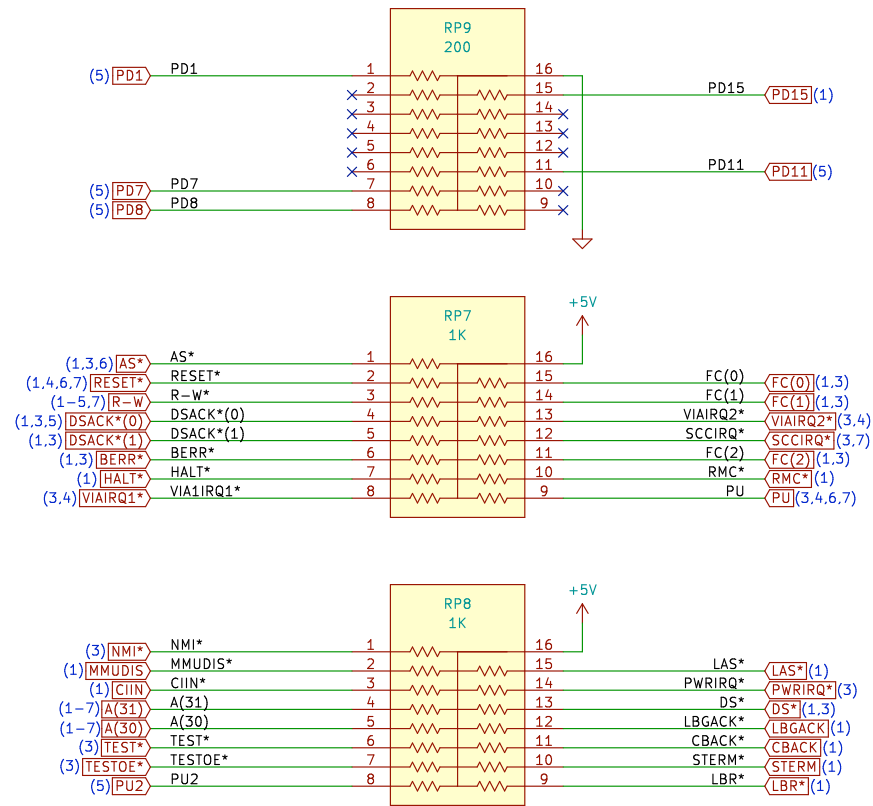
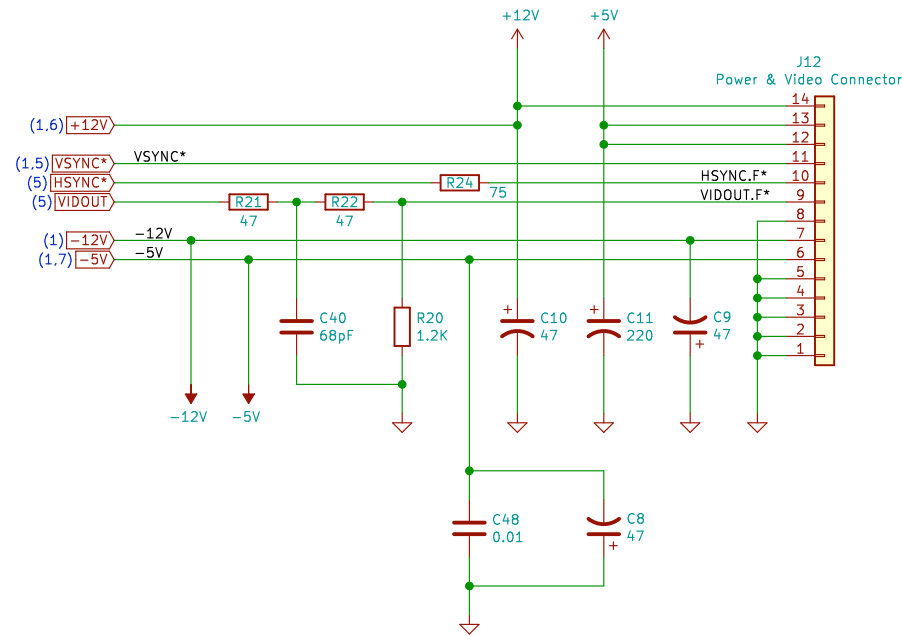

This page is referenced in the other drawings,
but its contents are unknown. It was possibly a
“bed of nails” flying probe schematic.

Recreation of Apple engineering drawing 050-0253-01

Sheet: /Unknown/
File: Unknown.sch

Title: Unknown

Size: USLedger Date: 2020-05-18

Rev: 1

KiCad E.D.A. kicad (5.1.6-0-10_14)

Id: 10/10

Macintosh SE/30 MLB Address Line Pin Matrix

Address	ROM	UJ2 RAM Mux	UI2 RAM Mux	UI3 RAM Mux	UJ3 RAM Mux	UJ4 RAM Mux	UI4 RAM Mux	UI8 GLUE	UK12 VIA1	UK11 VIA2	UK6 Vid ROM	UA8 Video Mux	UB8 Video Mux	UC8 Video Mux	UD8 Video Mux	UJ11 SWIM	UG12 Serial	UE10 Sound	UK8 CPU	UI5 FPU	J13 PDS Slot
A(0)								77			10				4			41	A2		116
A(1)								74			9				12		39	42	C4	25	76
A(2)	4	3,6									8			4			37	43	D13	24	36
A(3)	5	2,5									7			12				44	D12	23	115
A(4)	6	10,13									6		4					1	C13	22	75
A(5)	7	11,14									5		12					2	C12		35
A(6)	8		3,6								4	4						3	D11		114
A(7)	9		2,5								3	12						4	B13		34
A(8)	31		10,13								25				3			7	B12		113
A(9)	32		11,14						42	42	24				13	37		8	C11		73
A(10)	33			3,6					41	41	21			3		40		9	A13		33
A(11)	34			2,5					40	40	23			13		41		10	C10		112
A(12)	35			10,13					39	39	2		3			42			B11		72
A(13)	36			11,14				46					13						A12		32
A(14)	37				3,6			45											B10		111
A(15)	38				2,5			44											A11		31
A(16)	39				10,13			41											B9		110
A(17)	40				11,14			28											A10		70
A(18)	41					3,6													C8		30
A(19)	42					2,5													A9		109
A(20)	43					10,13		61											B8		69
A(21)	44					11,14													A8		29
A(22)	45						3,6	58											B7		108
A(23)							2,5												A7		28
A(24)							10,13	56											A6		107
A(25)							11,14	40											B6		67
A(26)								55											A5		27
A(27)								39											B5		106
A(28)								37											A4		66
A(29)								36											B4		26
A(30)								34											A3		105
A(31)								31											B3		25

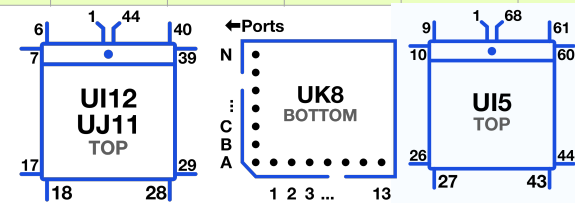
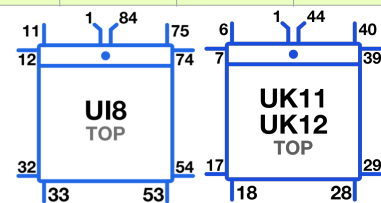

Macintosh SE/30 MLB Data Line Pin Matrix

Address	ROM	D4 Diode	D5 Diode	D6 Diode	D7 Diode	D8 Diode	D9 Diode	D10 Diode	D11 Diode	D12 Diode	D13 Diode	D14 Diode	D15 Diode	D16 Diode	D17 Diode	D18 Diode	D19 Diode	S1A RAM	S1B RAM	S2A RAM	S2B RAM	S3A RAM	S3B RAM	S4A RAM	S4B RAM	UK12 VIA1	UK11 VIA2	UK6 VROM	UC6 VRAM	UC7 VRAM	UJ11 SWIM	UI12 SCSI	UG12 Serial	UE10 DSC	UK8 CPU	UI5 FPU	J13 PDS				
D(0)	14	1															3				3															K13	3	13			
D(1)	15			1													6				6																K12	2	93		
D(2)	16					1											10				10																L13	1	14		
D(3)	17							1									13				13																M13	68	54		
D(4)	18									1							16				16																L12	67	94		
D(5)	19											1					20				20																K11	66	15		
D(6)	20													1			23				23																M12	65	55		
D(7)	21														1		25				25																L11	64	95		
D(8)	22	2																3				3															N13	62	16		
D(9)	23			2														6				6															M11	60	96		
D(10)	24					2												10				10																L10	59	17	
D(11)	25							2										13				13																N12	58	57	
D(12)	26									2								16				16																M10	57	97	
D(13)	27										2							20				20																N11	56	18	
D(14)	28													2				23				23																M9	55	58	
D(15)	29														2			25				25																N10	54	98	
D(16)	47		1																3				3															N9	50	19	
D(17)	48					1													6				6															M8	49	99	
D(18)	49							1											10				10																N8	48	20
D(19)	50									1									13				13																N7	47	60
D(20)	51										1								16				16																M7	46	100
D(21)	52													1					20				20																N6	45	21
D(22)	53														1				23				23																M6	44	61
D(23)	54															1			25				25																N5	42	101
D(24)	55		2																	3				3	36	36	11		5	4	28	1	22			M5	40	22			
D(25)	56					2														6				6	35	35	12		6	5	27	2	21			N4	39	102			
D(26)	57							2												10				10	34	34	13		19	8	26	44	20			N3	38	23			
D(27)	58									2										13				13	32	32	15		20	9	25	3	19			M4	37	63			
D(28)	59										2									16				16	31	31	16	5		13	24	43	18			N2	36	103			
D(29)	60													2						20				20	30	30	17	6		14	22	4	17			M3	35	24			
D(30)	61														2					23				23	29	29	18	19		15	21	42	16			L4	34	64			
D(31)	62															2				25				25	28	28	19	20		18	20	5	15			N1	33	104			

